

SPILL TRAYS • FLOORING • DRUM SPILL CONTAINMENT • CABINETS • BEAM PROTECTORS  
IBC SPILL CONTAINMENT • TROLLEYS AND CARTS

**ROMOLD LTD®**

specialist manufacturers of polyethylene products  
[www.romold.co.uk](http://www.romold.co.uk)

# ROMOLD LTD®

A UK manufacturer of high quality polyethylene products.



**A**T ROMOLD we have been designing and manufacturing rotational moulded products for over seven years. We are the UK's leading manufacturer of polyethylene spill containment products and we ship Worldwide.

Our ongoing product development programme has enabled us to expand our product range and reach new markets - through providing innovative and practical solutions.



“ We are committed to manufacturing high quality products and providing our customers with a fast, flexible and friendly service. ”

## Quality and Environmental Standards

Our Quality Management System for product design and manufacture is ISO 9001: 2000 accredited. Our commitment to the environment is evident through our environmentally conscious product design, our use of recyclable materials and our ISO 14001 accredited Environmental Management System.



## Trade Only

Being a Trade Only supplier means that ROMOLD can concentrate on manufacturing, product development and supporting our distributors. Working closely with our distributors we have improved existing products and introduced new ranges. We encourage distributor interaction and use the shared creativity and knowledge to meet customer needs and market demands.

### ROMOLD Distributors benefit from:

- High product availability through our large on-site stock
- Fast delivery direct to distributor or their client
- Flexible service that supports "bulk" and "no minimum" orders
- Quality products - available in a range of colours
- Support and advice on technical, product and regulatory matters
- Friendly UK solutions partner
- On-line product image facilities



# contents

Spill Trays	1-2
Bund Flooring	3
Drum Spill Containment	4-7
Drum Dollies & Trolleys	8
Pallet Converters	9
Racking Bund	10
IBC Spill Containment	11-13
Beam Protectors	14
Poly Cart & Poly Work Cart	15
Roll Holders	16
Maintenance Carts	17-18
Cabinets	19-20
Storage Bins & Drum Accessories	21-22
Product Specifications	23
Chemical Compatibility Guide	24

## Extensive Manufacturing and Storage Facilities



1,000m<sup>2</sup> production and development space with over 1,500 m<sup>2</sup> of warehousing.

## Rotational Moulded Products



A fabricated steel mould is filled with coloured polyethylene powder.



The mould is rotated in a specialised oven.



The powder transforms to liquid creating a plastic skin inside the mould.

The design and construction of the mould - the quantity, type and mix of powder; the temperature and exposure times - are all crucial factors in creating a successful product. The finished product is lightweight, durable, chemical resistant and fully recyclable.

## Storage Regulations

There are a growing number of strict environmental regulations and Codes of Practice covering the storage of industrial fluids such as oils, solvents and chemicals. Mandatory legislation comes with heavy penalties for any company found to be non-compliant. Our products are designed with EC and UK regulations in mind so we can advise on the most suitable products for a fully compliant solution.

For more information contact us or visit [www.romold.co.uk](http://www.romold.co.uk)

# SPILL TRAYS

Romold's practical spill tray range

Manufactured from 100% polyethylene, our Spill Tray range is the ideal solution for catching spills in the work area and the storage and handling of smaller drums and cans.

They are compact and lightweight and can fit into small areas. Spill Trays are strong and compatible with most liquids.

With sump capacities up to 145ltr, available in a range of sizes and colours, our Spill Tray range provide a practical, simple and safe solution for small liquid storage, handling and spillage needs.

## Applications

- Can tray
- Liquid dispensing work area
- Laboratory tray
- Truck and machinery leak spill tray
- Machine part cleaning
- Solvent ink storage
- Battery storage
- Chemical dosing point accessory



### BB25

length 550mm  
width 550mm  
height 110mm  
weight 5kg  
sump 27.5ltr

▲ designed for 1 x 25ltr container



### BB50

length 715mm  
width 460mm  
height 110mm  
weight 5.5kg  
sump 27.5ltr

▲ designed for 2 x 25ltr containers



### BB100

length 920mm  
width 720mm  
height 175mm  
weight 15kg  
sump 100ltr

▲ designed for 4 x 25ltr containers

Compatible with most liquids

## IDEAL FOR GENERAL "HOUSEKEEPING" AND SPILL CONTROL

### TTXS

length 598mm  
width 395mm  
height 50mm  
weight 2.5kg  
sump 8ltr



### TTXM

length 574mm  
width 390mm  
height 53mm  
weight 0.9kg  
sump 10ltr



### TTXL

length 1200mm  
width 550mm  
height 50mm  
weight 2.6kg  
sump 30ltr

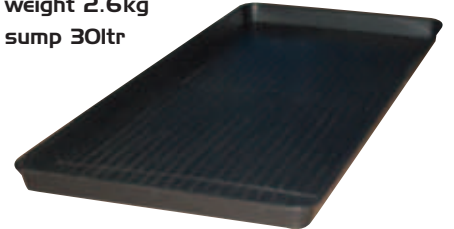

TTX range available  
only in grey

### TTS

length 630mm  
width 590mm  
height 170mm  
weight 4.5kg  
sump 45ltr



### TTHD

length 1460mm  
width 960mm  
height 120mm  
weight 20kg  
sump 145ltr



### TTL

length 1450mm  
width 840mm  
height 70mm  
weight 6kg  
sump 60ltr



Low profile, ideal for  
use under vehicles

## Romold's complete spill flooring solution

# BUND FLOORING

Our Bunded Flooring range is the flexible decking solution for creating liquid handling workstations and storage areas to fit your working environment.

Available in 3 sizes each unit can be used as a standalone workstation or combined to create multiple workflow configurations.

Each individual unit is compliant with current oil storage regulatory requirements -

- BF2 for up to 4 x 100ltr drums
- BF4 and BF4S for up to 4 x 205ltr drums each.

The low 150mm design and polyramp allows easy access for loading and unloading. An optional joint strip cover can be added for a superior finish and optional connectors to link unit sumps.

## Applications

- Modular workflow area
- Liquid dispensing workstation
- "Quarantine area" for leaking containers
- Drum storage & handling area
- Machine part cleaning area
- Ink storage bund
- Oil storage bund
- Lubricant treatment area

### BF4

length 1660mm  
width 1260mm  
height 150mm  
weight 40kg  
sump 300ltr  
UDL 2000kg

### BF2

length 1260mm  
width 860mm  
height 150mm  
weight 20kg  
sump 150ltr  
UDL 1000kg

### BFR

length 650mm  
width 800mm  
height 165mm  
weight 9kg

### BF4S

length 2610mm  
width 895mm  
height 150mm  
weight 48kg  
sump 300ltr  
UDL 2000kg

Only 150mm high



### BFC

Floor Connector

### BFS2 & BFS4

Floor Joining Strips for BF2's and BF4's. Not shown..

# DRUM SPILL CONTAINMENT

Romold's  
compliant drum  
bundled storage  
solutions

Our drum Bund Pallet range is designed for the safe and compliant storage of 205ltr drums.

Available in 1, 2, 3, 4 and 8 drum versions these robust, quality units are made from 100% polyethylene with broadband chemical compatibility.

## Features

- Corrosion free
- EC and UK Compliant Oil Storage
- Covered range for outdoors
- Removable plastic grids
- Compatible with most liquids
- Forklift pockets



### BPI

length 900mm  
width 700mm  
height 525mm  
weight 22kg  
sump 225ltr  
UDL 300kg

▲ designed for 1 x 205ltr drum



### BP2

length 1220mm  
width 820mm  
height 330mm  
weight 26kg  
sump 240ltr  
UDL 650kg

▲ designed for 2 x 205ltr drums



Double thickness  
outer edge

Extra ribbed design  
for added strength

### BP2HD

length 1290mm  
width 875mm  
height 345mm  
weight 40kg  
sump 240ltr  
UDL 2400kg

◀ heavy duty spill pallet  
designed for 2 x 205ltr drums



**BP3**

length 1785mm  
width 780mm  
height 240mm  
weight 35kg  
sump 228ltr  
UDL 900kg

◀ designed for 3 x 205ltr drums

**BP4**

length 1310mm  
width 1310mm  
height 370mm  
weight 44kg  
sump 410ltr  
UDL 1250kg



▲ designed for 4 x 205ltr drums

**BP4L**

length 1280mm  
width 1280mm  
height 275mm  
weight 35kg  
sump 230ltr  
UDL 1250kg



Ultra low profile

▲ designed for 4 x 205ltr drums



**BP8**

length 2560mm  
width 1350mm  
height 510mm  
weight 136kg  
sump 1140ltr  
UDL 2500kg

designed for  
8 x 205ltr drums  
or 2 x 1000ltr IBC's ▶

designed for  
3 x 205ltr drums ▶



### BP3C

length 1785mm  
width 780mm  
height 1945mm  
weight 65kg  
sump 228ltr  
UDL 900kg

designed for  
4 x 205ltr drums ▶



 Covers protect bund  
from rainwater

### BP4C

length 1415mm  
width 1310mm  
height 2070mm  
weight 54kg  
sump 410ltr  
UDL 1250kg

designed for  
8 x 205ltr drums  
or 2 x 1000ltr IBC's ▶



### BP8C

length 2560mm  
width 1350mm  
height 2210mm  
weight 156kg  
sump 1140ltr  
UDL 2500kg

**DBC**

length 1240mm  
width 795mm  
height 370mm  
weight 25kg  
UDL 600kg



◀ DBC stacker now only available in black.

This versatile system maximises floor space by stacking up to 4 steel drums horizontally above a one piece 400 ltr sump. Dispense from any of the drums in the safe knowledge that any leaks or spills will be contained.

**DB4**

length 1390mm  
width 1250mm  
height 490mm  
weight 50kg  
sump 400ltr  
UDL 1250kg

Ensure your drums are fully banded even when being transported.

Simple to use one person operation.

Dispense without the worry of spills.

**BT230**

length 1600mm  
width 740mm  
height 640mm  
weight 44kg  
sump 230ltr  
UDL 300kg



**CP2/S/H**

length 1630mm  
width 940mm  
height 1420mm  
weight 95kg  
sump 260ltr  
UDL 600kg



◀ **CP2S**

Complete with grid & shelf for storing 5 and 25ltr cans.



◀ **CP2**

Store your drums outside in this robust covered sump pallet. Holds 2 x 205ltr drums in the vertical position.

**CP2H**

Complete with a horizontal cradle for storing and dispensing a single 205ltr drum. Not shown.

## Versatile Bunded Dollies and Trolleys

# VERSATILE BUNDED DOLLIES & TROLLEYS

The Poly Drum Dollies are a safe and robust solution for moving 205ltr drums. The PDDH includes a steel handle making it ideal for moving smaller containers, boxes and batteries.

The Bunded Trolley was designed to safely transport up to four 25ltr drums but it has numerous other uses throughout the workplace.

## Features & Applications

- Made from sturdy 100% polyethylene
- Ideal for drums and smaller containers
- Lightweight and easy to handle
- Broadband chemical compatibility
- 4 castors for added stability - 2 lockable
- Sump base to contain spills



### PDD

length 725mm  
width 725mm  
height 255mm  
weight 14kg  
sump 30ltr  
UDL 300kg



### PDDH

length 725mm  
width 725mm  
height 990mm  
weight 15.5kg  
sump 30ltr  
UDL 300kg



### BT100

length 900mm  
width 700mm  
height 980mm  
weight 18kg  
sump 100ltr  
UDL 100kg



# PALLET CONVERTER

Turn a standard pallet into a bunded pallet

Place the Palcon over an existing pallet and it is ready to use. The unique compressible front allows drums on a pallet to be lowered into the Palcon by a forklift truck. When the forks are withdrawn the front returns to its normal height creating the bund.

## Features

- Made from flexible plastomer
- Lightweight and easy to handle
- 2 drum and 4 drum versions
- Broadband chemical compatibility
- Compliant with UK Oil Storage Regulations
- Unique compressible front

### PALCON2

length 1500mm  
width 1100mm  
height 440mm  
weight 20kg  
sump 250ltrs



Palcon2 must be used with 1200mm x 800mm wooden or plastic pallets

### PALCON4

length 1500mm  
width 1300mm  
height 440mm  
weight 22kg  
sump 310ltrs



Palcon4 must be used with 1200mm x 1000mm wooden or plastic pallets

### Easy three stage operation



# RACKING BUND

Turn  
standard  
racking into  
bunded racking

Turn standard pallet racking into bunded racking with Romold's Rack Bund.

Made from 100% polyethylene, the racking bund sits across the beams and the pallet sits inside the bund.

Simple and fully compliant racking bund solution.

## Features

- Stop leaks damaging other products
- Segregate pollutants and materials
- Use with existing racking
- Broadband chemical compatibility
- Sits on cross beams
- EC and UK compliant

### RBI

length 1310mm  
width 1310mm  
height 245mm  
weight 25kg  
sump 220ltr

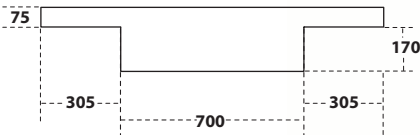

- ▲ simply sits across the beams whilst the pallet sits inside the bund



# IBC SPILL CONTAINMENT

Romold's compliant IBC bunded storage solutions

Our extensive IBC Spill Containment range is specifically designed to meet the growing IBC end user market. Made from 100% corrosion free polyethylene, these sturdy units are EC and UK compliant.

We produce single and double IBC units, dispensing and filling accessories and outdoor versions.

## Features

- Corrosion resistant
- Suitable for most IBC footprints
- Fork pockets for moving empty units
- Removable decking to assist cleaning
- Robust 100% polyethylene construction



### BBI

length 1760mm  
width 1350mm  
height 710mm  
weight 107kg  
sump 1100ltr  
UDL 1500kg



Sturdy single IBC secondary containment solution with removable grid and optional overflow tray

▲ suitable for 1 x 1000ltr IBC



### BBIT

length 525mm  
width 545mm  
height 835mm  
weight 8.5kg  
sump 86ltr

overflow tray for use with BBI - overflows into main sump



### BBID

length 1950mm  
width 1400mm  
height 725mm  
weight 86kg  
sump 1100ltr  
UDL 1500kg



Fully compliant single IBC secondary containment solution with integral dispensing area

Outdoor storage of any type of oil greater than 200 litres must have a secondary containment system or bund

The bund must be sufficient to contain 110% of the maximum contents of the oil container

### BBIC

length 1760mm  
width 1350mm  
height 2410mm  
weight 119kg  
sump 1100ltr  
UDL 1500kg

single IBC bund complete with frame and cover - shown with optional BBIT overflow tray





**BB2**

length 2560mm  
width 1350mm  
height 510mm  
weight 136kg  
sump 1140ltr  
UDL 2500kg

◀ double IBC secondary containment solution - can also take up to 8 x 205ltr drums

▲ shown with optional BB2T overflow tray



**BB2C**

length 2560mm  
width 1350mm  
height 2210mm  
weight 156kg  
sump 1140ltr  
UDL 2500kg

double IBC secondary containment solution complete with frame and cover

↪ protects IBC bund from rainwater



**BB2T**

length 530mm  
width 510mm  
height 560mm  
weight 4kg  
sump 86ltr

▲ overflow tray for use with BB2



**DF200**

640mm diam.  
height 150mm  
weight 4kg

▲ IBC funnel with lid and integral debris strainer

# UNIVERSAL BEAM PROTECTORS

Protect your building columns

Romold's Universal Beam Protectors are manufactured from robust 100% polyethylene.

Designed for quick and simple fitting.

Protect your building columns and your forklift trucks.

Features

- Hi-vis yellow
- Maintenance free
- Bolts together in minutes
- Fits most universal beams

See page 23 for heights and weights of UBP's.

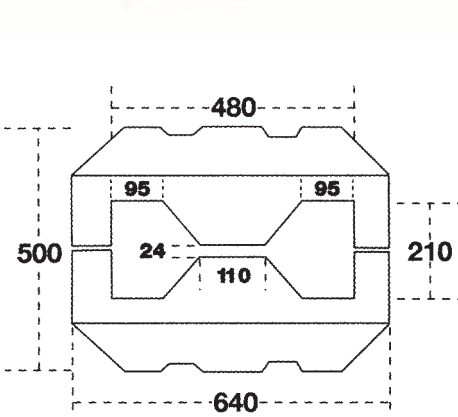

**UBP1**

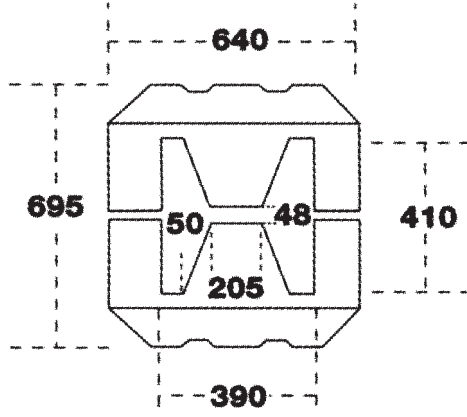

**UBP2**

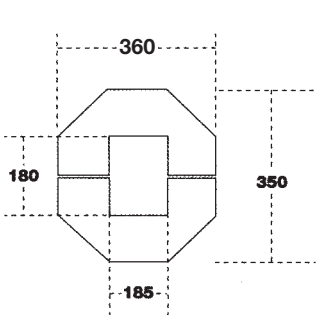

**UBP3**

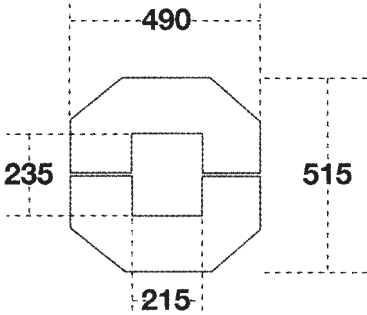

**UBP4**

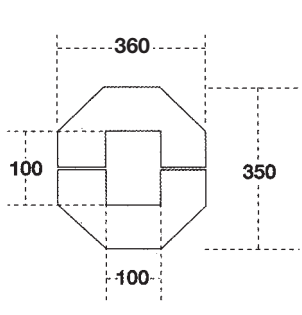

**UBP5**

# POLY CART AND POLY WORK CART

**Flexible solutions with Romold's carts**

The Poly Cart provides a simple, fast and effective solution for cleaning up oil spills in the workplace or treating snow and ice on pavements and car parks.  
 The Poly Work Cart is a robust mobile workstation suitable for general maintenance and repair applications across all sectors.

**Features & Applications**

- Made from 100% polyethylene
- For indoor and outdoor use
- Lightweight and easy to manoeuvre
- Easy push rear handle
- Versatile carts with numerous uses
- Broadband chemical compatibility
- Lockable door

**PC**  
 length 1360mm  
 width 710mm  
 height 965mm  
 weight 40kg  
 capacity 60lts



- Front hopper for sorbent granules, salt or grit - fitted with a lid
- Rear waste bag holder with lid
- A must have housekeeping cart

**PWC4**  
 length 640mm  
 width 725mm  
 height 1075mm  
 weight 27kg



**Lockable front wheels**

- Top external tray with central divide
- Internal storage on two levels with removable tray
- A must have maintenance cart

# POLY ROLL HOLDER

## Worktop dispensing units

The Poly Roll Holder is a flexible and robust roll dispenser that accepts all standard absorbent and paper rolls.

Ideal for environments where spills are likely and a fast cleanup is essential. Suitable for janitorial, engineering and general maintenance applications across all sectors.

The Poly Roll Holder can be placed on a worktop or fitted on top of the Poly Work Cart to create a mobile spill station and total maintenance cart.

## Features

- Made from 100% polyethylene
- Standalone unit or fits on Work Cart
- Accepts all standard roll sizes
- Maintain a clean work environment
- Lightweight and easy to move
- Broadband chemical compatibility
- Easy dispensing action
- Reduce risk of accidents



### ◀ PRHS

length 640mm  
width 560mm  
height 570mm  
weight 8kg  
max roll 430mm diam.  
500mm wide



### PRHL

length 640mm  
width 625mm  
height 580mm  
weight 10kg  
max roll 480mm diam.  
520mm wide



All roll holders fit on top of Poly Work Cart



### ◀ PRHXL

length 640mm  
width 635mm  
height 615mm  
weight 11kg  
max roll 550mm diam.  
520mm wide



# POLY MAINTENANCE CART

## Romold's mobile maintenance station

The Poly Maintenance Cart is a flexible and robust maintenance unit suitable for general maintenance and spill management applications across all sectors.

The unit has secure internal storage for drums and containers with a convenient slotted opening in the door for gloves and manuals. The top of the unit is complete with a roll holder and hinged lid. The roll holder is suitable for absorbent rolls, general paper rolls or wipes.

## Features

- Made from 100% polyethylene
- For indoor and outdoor use
- Upper storage level suitable for 5ltr cans or absorbent pads
- Easy loading top roll holder
- Lightweight and easy to handle
- Broadband chemical compatibility
- Lower storage level suitable for 20 to 25ltr plastic drums or absorbent socks
- Lockable door

### PMCS4

length 640mm  
width 725mm  
height 1520mm  
weight 34kg  
max roll 430mm diam.  
500mm wide





## PMCL4

length 650mm  
width 725mm  
height 1520mm  
weight 37kg  
max roll 480mm diam.  
520mm wide

Lightweight  
and easy to  
handle

Suitable for indoor and outdoor use

lockable front wheels



## PMCXL4

length 650mm  
width 725mm  
height 1550mm  
weight 39kg  
max roll 550mm diam.  
520mm wide



# CABINETS

Polyethylene storage cabinets

A wide range of polyethylene cabinets all with lockable doors and built-in sumps.

Suitable for a wide variety of storage applications.

Cabinets available in different solid colours.

PSCI, PSC2 and PSC5 models also available in mixed body and door colours.

## Features & Applications

- 100% polyethylene
- Lockable doors
- Low maintenance
- Integral sumps



### PSC2

length 650mm  
width 570mm  
height 1650mm  
weight 40kg  
sump 70ltr



### PSCI

length 545mm  
width 440mm  
height 990mm  
weight 15kg  
sump 30ltr





**PSC3**  
length 720mm  
width 920mm  
height 1835mm  
weight 56kg  
sump 225ltr

EC and UK  
compliant  
bund storage



**PSC4**  
length 720mm  
width 920mm  
height 1835mm  
weight 60kg  
sump 225ltr

Secure  
storage with  
integral sump

Supplied with shelf



**PSC5**  
length 720mm  
width 920mm  
height 1520mm  
weight 52kg  
sump 100ltr

# POLY STORAGE BINS

## Multi use storage bins

Large capacity Poly Storage Bins for both indoor and outdoor use. Robust polyethylene construction with base forklift pockets makes them easy to clean bins ideal for storing a wide range of products including powders, liquids, waste products, spill kits and equipment.



### PSBI

length 1265mm  
width 855mm  
height 910mm  
weight 26kg  
capacity 350ltr



PSBI's and PSBIW's come as standard with a lid. Pictures show these units fitted with the optional lid lock and hinge kit code PSBLH - see below



### PSBIW

length 1265mm  
width 855mm  
height 950mm  
weight 31kg  
capacity 350ltr  
(not watertight)



### PSB2

length 1460mm  
width 1010mm  
height 975mm  
weight 35kg  
capacity 1000ltr



PSB2's and PSB2W's come as standard with a lid and a lid lock and hinge kit. See below for more details.



### PSB2W

length 1460mm  
width 1010mm  
height 1015mm  
weight 40kg  
capacity 1000ltr

### PSBLH

If a lockable hinged lid is required with either the PSBI or the PSBIW please order our lid lock and hinge kit code PSBLH. This kit comes as standard with models PSB2 and PSB2W. In all cases the kits are supplied in component form as are the wheels if the PSBIW or PSB2W are ordered, these will need simple fitting on delivery; fixings and instructions are provided, all holes required are pre drilled.

## DRUM ACCESSORIES

### Romold's Drum Funnels and lids

Our Drum Funnels, Lids and Tray provide simple ways to collect liquids, keep drum tops dry and help prevent spills.

They are manufactured from easy to clean polyethylene and are compatible for use with most liquids - see page 24 for further details.

drum lid



#### DLI

650mm diam.  
height 70mm  
weight 2kg

drum funnel  
& lid



#### DF50

560mm diam.  
height 130mm  
weight 3kg

drum funnel with  
integral debris  
strainer & lid



#### DFI

610mm diam.  
height 230mm  
weight 4kg

drum tray

#### BT50

870mm diam.  
height 190mm  
weight 5kg  
sump 50ltr

A Funnel and Lid for IBC's model DF200, can be found on page 13.

## MULTI USE STORAGE CONTAINER



#### 1500BIN

length 1610mm  
width 1095mm  
height 1020mm  
weight 50kg  
capacity 1500ltr



Optional  
cradle  
increases  
rigidity.  
Fork-liftable  
and stackable.

A 1500ltr capacity bin for numerous open storage applications,  
a lid is not currently available for this unit nor is a wheeled version.

# Product Specifications (Dimensions may vary by +- 3%)

Code	Description	Bund Capacity (ltr)	L x W x H (mm)	Weight (kg) / Max Load UDL (kg)
BB25	Spill Tray suitable for 1 x 25ltr can	27.5	550 x 550 x 110	5
BB50	Spill Tray suitable for 2 x 25ltr can	27.5	715 x 460 x 110	5.5
BB100	Spill Tray suitable for 4 x 25ltr can	100	920 x 720 x 175	15
TTXS	Truck Tray XS drip tray	8	598 x 395 x 50	2.5
TTXM	Truck Tray XM drip tray	10	574 x 390 x 53	0.9
TTXL	Truck Tray XL drip tray	30	1200 x 550 x 50	2.6
TTS	Truck Tray Small drip tray	45	630 x 590 x 170	4.5
TTL	Truck Tray Large drip tray	60	1450 x 840 x 70	6
TTHD	Truck Tray Heavy Duty drip tray	145	1460 x 960 x 120	20
BF2	Bunded Floor suitable for 2 x 205ltr drums	150	1260 x 860 x 150	20 / 1000
BF4	Bunded Floor suitable for 4 x 205ltr drums	300	1660 x 1260 x 150	40 / 2000
BF4S	Bunded Floor suitable for 4 x 205ltr drums in line	300	2610 x 895 x 150	48 / 2000
BFR	Bund Floor Ramp for all floors	-	650 x 800 x 165	9
BFC	Bunded Floor Connector for all floors	-	-	-
BFS2	Bunded Floor joining strip for 2no BF2's	-	-	-
BFS4	Bunded Floor joining strip for 2no BF4's	-	-	-
BP1	Bunded Pallet suitable for 1 x 205ltr drum	225	900 x 700 x 525	22 / 300
BP2	Bunded Pallet suitable for 2 x 205ltr drums	240	1220 x 820 x 330	26 / 650
BP2HD	Heavy Duty Bunded Pallet for 2 x 205ltr drums	240	1290 x 875 x 345	40 / 2400
BP3	Bunded Pallet suitable for 3 x 205ltr drums	228	1785 x 780 x 240	35 / 900
BP4	Bunded Pallet suitable for 4 x 205ltr drums with extra bund capacity	410	1310 x 1310 x 370	44 / 1250
BP4L	Bunded Pallet suitable for 4 x 205ltr drums with ultra low profile	230	1280 x 1280 x 275	35 / 1250
BP8	Bunded Pallet suitable for 8 x 205ltr drums	1140	2560 x 1350 x 510	136 / 2500
BP3C	Bunded Pallet & Cover suitable for 3 x 205ltr drums, self assembly frame & cover	228	1785 x 780 x 1945	65 / 900
BP4C	Bunded Pallet & Cover suitable for 4 x 205ltr drums, self assembly frame & cover	410	1415 x 1310 x 2070	54 / 1250
BP8C	Bunded Pallet & Cover suitable for 8 x 205ltr drums, self assembly frame & cover	1140	2560 x 1350 x 2210	156 / 2500
DB4	Dispensing Bund suitable for 2 x 205ltr drums	400	1390 x 1250 x 490	50 / 1250
DBC	Dispensing Bund Cradle suitable for 2 x 205ltr drums	-	1240 x 795 x 370	25 / 600
BT230	Bunded Trolley - storage, transport and dispensing of single 205ltr drum	230	1600 x 740 x 640	44 / 300
CP2	Hard Covered Bunded Pallet suitable for 2 x 205ltr drums	260	1630 x 940 x 1420	95 / 600
CP2S	Hard Covered Bunded Pallet with shelf for storing 5ltr and 25ltr cans	260	1630 x 940 x 1420	95 / 600
CP2H	Hard Covered Bunded Pallet with cradle for a single 205ltr drum	260	1630 x 940 x 1420	95 / 600
PDD	Polly Drum Dolly on 4 wheels, suitable for moving 205ltr drums	30	725 x 725 x 255	14 / 300
PDDH	Polly Drum Dolly on 4 wheels with handle, suitable for moving 205ltr drums etc	30	725 x 725 x 990	15.5 / 300
BT100	Bunded Trolley suitable for 4 x 25ltr cans	100	900 x 700 x 980	18 / 100
PALCON2	Pallet Converter, turns a standard wooden pallet into a bunded pallet for 2 drums	250	1500 x 1100 x 440	20
PALCON4	Pallet Converter, turns a standard wooden pallet into a bunded pallet for 4 drums	310	1500 x 1300 x 440	22
RB1	Bund used to convert standard racking into bunded racking	220	1310 x 1310 x 245	25
BB1	Bunded Pallet suitable for 1 x 1000ltr IBC	1100	1760 x 1350 x 710	107 / 1500
BB1T	Dispensing Tray for BB1, pot and base - overflows into main sump	86	525 x 545 x 835	8.5
BB1D	Bunded Pallet with integral dispenser suitable for 1 x 1000ltr IBC (no grid)	1100	1950 x 1400 x 725	86 / 1500
BB1C	Bunded Pallet suitable for 1 x 1000ltr IBC, self assembly frame and cover	1100	1760 x 1350 x 2410	119 / 1500
BB2	Bunded Pallet suitable for 2 x 1000ltr IBC	1140	2560 x 1350 x 510	136 / 2500
BB2C	Bunded Pallet suitable for 2 x 1000ltr IBC, self assembly frame and cover	1140	2560 x 1350 x 2210	156 / 2500
BB2T	Dispensing Tray for BB2 - overflows into main sump	86	530 x 510 x 560	4
DF200	IBC Funnel with integral debris strainer	-	640 dia x 150	4
UBP1	Universal Beam Protector - max size 480 x 210mm	UBP1	500 x 640 x 985	34
UBP2	Universal Beam Protector - max size 390 x 410mm	UBP2	695 x 640 x 985	39
UBP3	Universal Beam Protector - max size 185 x 180mm	UBP3	350 x 360 x 950	12
UBP4	Universal Beam Protector - max size 235 x 215mm	UBP4	515 x 490 x 950	18
UBP5	Universal Beam Protector - max size 100 x 100mm	UBP5	350 x 360 x 950	12
PC	Poly Cart - Dispensing Cart for loose material with stowage for brush and shovel	-	1360 x 710 x 965	40
PWC4	Poly Work Cart - Mobile work station on 4 wheels with lockable door	-	640 x 725 x 1075	27
PRHS	Poly Roll Holder Small - max roll size 430mm dia. 500mm wide, fits on PWC & PWC4	-	640 x 560 x 570	8
PRHL	Poly Roll Holder Large - max roll size 480mm dia. 520mm wide, fits on PWC & PWC4	-	640 x 625 x 580	10
PRHXL	Poly Roll Holder XLarge - max roll size 550mm dia. 520mm wide, fits on PWC & PWC4	-	640 x 635 x 615	11
PMCS4	Poly Maintenance Cart Small - Mobile spill station on 4 wheels with shelf & lockable door	-	640 x 725 x 1520	34
PMCL4	Poly Maintenance Cart Large - Mobile spill station on wheels with shelf & lockable door	-	650 x 725 x 1520	37
PMCXL4	Poly Maintenance Cart XLarge - Mobile spill station on 4 wheels with shelf & lockable door	-	650 x 725 x 1550	39
PSC1	Small Storage Cabinet, lockable with 2 shelves	30	545 x 440 x 990	15
PSC2	Medium Storage Cabinet, lockable with 3 shelves	70	650 x 570 x 1650	40
PSC3	Lockable Storage Cabinet suitable for single 205ltr drum (vertical)	225	720 x 920 x 1835	56
PSC4	Lockable Storage Cabinet with shelf	225	720 x 920 x 1835	60
PSC5	Lockable Storage Cabinet with shelf	100	720 x 920 x 1520	52
PSB1	Storage Bin with Lid, 350ltr capacity	-	1265 x 855 x 910	26
PSB1W	Wheeled Storage Bin with Lid, 350ltr capacity	-	1265 x 855 x 950	31
PSBLH	Optional Lid Lock & Hinge Kit for PSB1 and PSB1W	-	-	-
PSB2	Storage Bin with Lockable Hinged Lid, 1000ltr capacity	-	1460 x 1010 x 975	35
PSB2W	Wheeled Storage Bin with Lockable Hinged Lid, 1000ltr capacity	-	1460 x 1010 x 1015	40
1500BIN	Large Poly Storage Bin, 1500ltr capacity - optional steel cradle	-	1610 x 1095 x 1020	50
DL1	205ltr Drum Lid	-	650 dia x 70	2
DF1	205ltr Drum Funnel/Lid with integral debris strainer	-	610 dia x 230	4
DF50	205ltr Drum Funnel/Lid with integral debris strainer - suitable for closed head drums	-	560 dia x 130	3
BT50	Drum Bund Tray	50	870 dia x 190	5

# Polyethylene Chemical Compatibility Guide

Acetaldehyde 40%	Butanol	Fluosilicic Acid	Methyl Amine 32%	Selenic Acid
Acetamide	Butyl Acetate	Formaldehyde 40%	Methyl Sulphate	Silicic Acid
Acetic Acid 10%	Butyl Alcohol	Formamide	Methyl Sulphuric Acid	Silver Nitrate
Acetone	Butylene Glycol	Formic Acid	Monochloroacetic Acid Ethyl Ester	Sodium Acetate sat.sol
Acrylonitrile	Butyric Acid	Fruit Pulp sol	Monnchloroacetic Acid Methyl Ester	Sodium Acrylates
Adipic Acid	Calcium Carbonate sat.sol	Furfural	Morpholin	Sodium Benzoate
Aliphatic Hydrocarbons	Calcium Chloride	Gallic Acid sat.sol	MowilithD	Sodium Bicarbonate
Allyl Alcohol 96%	Calcium Hydroxide	Gluconic Acid	Muriatic Acid	Sodium Bisulphate sat.sol
Alum (aqu.sol)	Calcium Hypochlorite sol	Glycerine	Nickel Chloride sat.sol	Sodium Bisulphite
Aluminium Chloride sat.sol	Calcium Nitrate 50%	Glycol	Nicotine Dilute	Sodium Bromide
Aluminium Fluoride	Calcium Sulphate sat.sol	Glycol Ethers	Nicotinic Acid	Sodium Carbonate
Aluminium Hydrogen sol 10%	Carbonic Acid (Aq.CO2)	Glycolic Acid	Nitric Acid 25%	Sodium Chlorate
Aluminium Hydroxide	Carbon Monoxide	Heptane	n-Octane	Sodium Chloride
Aluminium Sulphate sat.sol	Caustic (Aqueous)	Hexane	Octyl Cresol	Sodium Chromate
Ammonia (Anhydrous)	Caustic Potash Sol. 50%	Hexanel Tert	Oleic Acid	Sodium Chlorophite
Ammonia (aqu.sol)	Caustic Soda Sol. 10%	Hydrazine Hydrate	Orthophosphoric Acid 50%	Sodium Dithionite10%
Ammonia (100% Dry Gas)	Chloral Hydrate	Hydrosulphite 10%	Oxalic Acid	Sodium Ferricyanide
Ammonium Acetate	Chloroethanol	Hydroxylamine Sulphate	Paraffin Emulsions	Sodium Ferrocyanide sat.sol
Ammonium Bifluoride	Chloric Acid 10%	Hydrazine 35%	Paraffin Oil	Sodium Fluoride sat.sol
Ammonium Carbonate 50%	Chloroacetic Acid	Hydrazine Hydrochloride	Perchloric Acid 20%	Sodium Hydroxide Conc.
Ammonium Chloride	Chlorobenzene	Hydroiodic Acid	Phosphoric Acid 50%	Sodium Hypochlorite
Ammonium Hydrogen Fluoride 50%	Chrome Alum sat.sol	Hydrobromic Acid 50%	Phosphorous Yellow	Sodium Iodide
Ammonium Hydroxide	Chromic Acid sat.sol	Hydrocyanic Acid sat.sol	Phosphorous Pentoxide	Sodium Nitrate
Ammonium Metaphosphate sat.sol	Citric Acid 25%	Hydrochloric Acid 36%	Phtalic Acid	Sodium Oxalate
Ammonium Nitrate sat.sol	Clorox Bleach	Hydrofluoric Acid 40%	Phtalic Anhydride	Sodium Persulphate
Ammonium Persulphate sat.sol	Copper Cyanide	Hydrofluorosilicic Acid	Picric Acid 1%	Sodium Phosphate
Ammonium Phosphate	Copper Nitrate	Hydrogen Bromide 10%	Potash	Sodium Silicate
Ammonium Sulphide sat.sol	Copper Sulphate	Hydrogen Peroxide 90% Sulphates 50%	Potassium/Aluminum	Sodium Sulphate
Ammonium Thiocyanate sat.sol	Cresol 90%	Hydrogen Phosphide 100%	Potassium Bichromate	Sodium Sulphide
Amyl Acetate	Cresylic Acid	Hydrogen Sulphide	Potassium Borate 10%	Sodium Sulphonates
Amyl Alcohol	Crotonic Aldehyde	Hypochlorous Acid	Potassium Bromide	Sodium Thiosulphate
Antimony Salts	Cuprous Chloride sat.sol	Iodine (Alc. Sol.) Conc	Potassium Chlorate	Starch Solution sat.sol
Antimony Trichloride 90%	Cyclohexane	Iron (II) Chloride sat.sol	Potassium Chloride	Stearic Acid
Aqueous Alkalies (NaOH)	Cyclohexanol	Iron (II) Sulphate sat.sol	Potassium Chromate	Succinic Acid
Arsenic Acid	Dextrin sat.sol	Iron (III) Chloride sat.sol	Potassium Cyanide	Sulphur
Asorbic Acid 10%	Dextrose sat.sol	Iron (III) Nitrate sat.sol	Potassium Dichromate 40%	Sulphuric Acid 50%
Barium Carbonate sat.sol	Diethyl Carbonate	Iron (III) Sulphate sat.sol	Potassium Fluoride	Tannic Acid sol
Barium Chloride	Disodium Phosphate	Isopropanol	Potassium Hydroxide	Tanning Extracts
Barium Cyanide	Diethylene Glycol	Isopropyl Acetate	Potassium Iodide	Tartaric Acid sat.sol
Barium Hydroxide sat.sol	Diglycolic Acid 30%	Isopropyl Alcohol	Potassium Nitrate sat.sol	Tetraethyl Lead
Barium Nitrate	Dioxane	Lactic Acid (All Conc)	Potassium Perborate sat.sol	Tributylprophate
Barium Sulphate sat.sol	Electrolyte	Lead Acetate sat.sol	Potassium Perchlorate	Tricresyl Phosphate
Barium Sulphide	Ethanol	Magnesium Carbonate	Potassium Permanganate	Triethanolamine
Battery Fluid, Acid	Ethyl Alcohol	Magnesium Hydroxide	Potassium Persulphate sat.sol	Trisodium Phosphate sat.sol
Benzaldehyde	Ethylene Chlorohydrin	Magnesium Nitrate	Potassium Phosphates	Urea
Benzene Ethylene Diamine	Magnesium Oxide	Potassium Sulphate	Wetting Agents	
Benzoic Acid	Ethylene Glycol	Magnesium Sulphate	Propanol	White Acid 75%
Benzyl Alcohol	Ferric Chloride sat.sol	Maleic Acid	Propargyl Alcohol 7%	Yeast sol
Benzyl Chloroformate	Ferric Nitrate sat.sol	Malic Acid 1%	Propionic Acid 50%	Zinc Bromide sat.sol
Boric Acid Dilute	Ferric Salts	Mercury	Propyl Alcohol	Zinc Chloride sat.sol
Boric Acid Conc	Ferric Sulphate sat.sol	Methanol	Propylene Dichloride	Zinc Sulphate
Butadiene	Ferrous Sulphate	Methyl Acetate	Propylene Glycol	
Butanediol	Fluoboric Acid	Methyl Alcohol	Propylene Oxide	

Polyethylene products are compatible for use with the substances and concentration levels shown above. This guide was compiled from various sources as an information aid only. No tests have been conducted to validate the information and we assume no responsibility or liability for the use or misuse of this information.

# **ROMOLD LTD<sup>®</sup>**

Grangemouth Road  
Bo'ness  
West Lothian  
EH51 OPZ  
U.K.

telephone: +44 (0) 1506 829623

facsimile: +44 (0) 1506 828639

email: [enquiries@romold.co.uk](mailto:enquiries@romold.co.uk)

**[www.romold.co.uk](http://www.romold.co.uk)**

